

Congratulation on selecting DARALI® Drives as the choice for your power transmission needs. This *Installation, Operation, and Maintenance Manual*, together with the product literature, will provide you relevant information to assure a long lasting trouble free operation. All units are tested and checked prior to shipment; a great deal of care is taken in packaging and shipping arrangements to ensure that the unit arrives at the customer in the approved condition. Please read this manual thoroughly, and perform all necessary procedures in order to achieve optimum performance. Thank you for selecting DARALI® Cycloidal Reducers. Should you have any question, contact us via phone or fax.

Manufactured By:
DARALI GROUP (ISO-9002)
 No. 136 Tung-Shan 3rd Road
 Tainan Hsien, Taiwan, ROC
 Phone: 886-6-6335817
 Fax: 886-6-6330081

North American Distribution By:
PTC ENDEAVOR, INC. - DARALI DRIVES
 4220 Steve Reynolds Blvd., Suite 18
 Norcross, GA 30093 USA
 Phone: (770) 381-6888
 Fax: (770) 381-5386

Table of Contents

- ◆ Name Plate 1
- ◆ Part Number Nomenclature 2
- ◆ Before You Start 3
- ◆ Daily Inspection 4
- ◆ Lubrication (Oil) 5
- ◆ Lubrication (Grease) 6
- ◆ Installation 7 ~ 8
- ◆ Parts List - Single Reduction (6:1 ~ 87:1) 9 ~ 10
- ◆ Parts List - Double Reduction (102:1 ~ 7569:1) 11 ~ 12
- ◆ Standard Motor Characteristics 13
- ◆ Brakemotor Wiring Diagram 14

Name tag for frame sizes B07 ~ B09

DARALI CYCLOIDAL REDUCERS		SERIAL NO:	
MODEL:	INPUT:	RATIO:	HP:
DARALI GROUP (ISO-9002)			

Name plate for frame sizes B10 ~ B27

DARALI™			
CYCLOIDAL REDUCERS			
MODEL			
INPUT		HP	
RATIO		INCH-LB	
NO.			
Manufactured by DARALI GROUP (ISO-9002) North American Distribution by PTC Endeavor, Inc.			

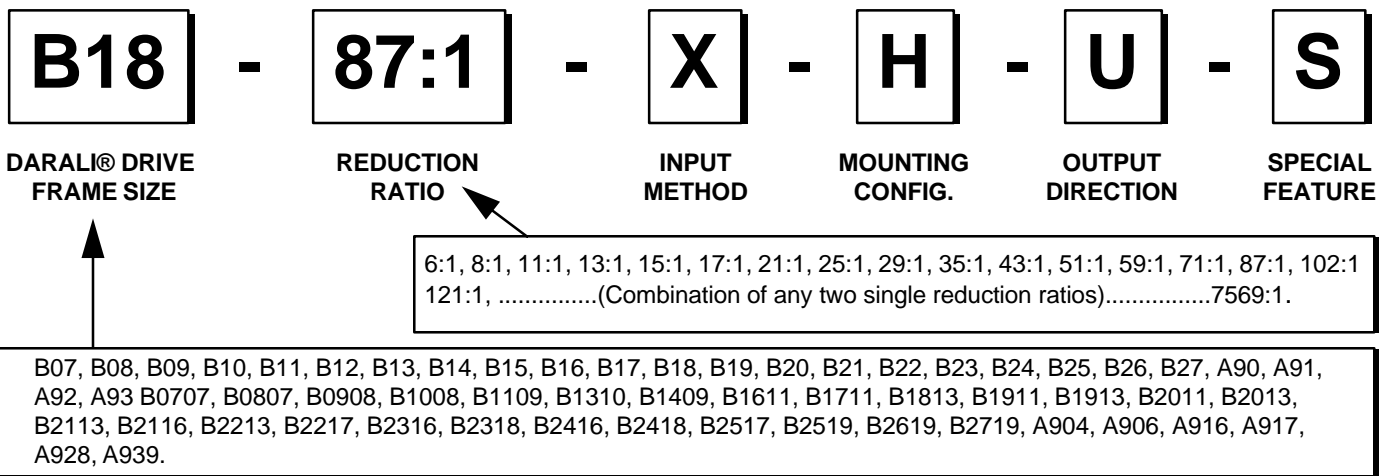

◆ FRAME SIZE AND REDUCTION RATIO

Single reduction ratios from 6:1 ~ 87:1, double reduction ratios from 102:1 ~ 7569:1.

◆ INPUT METHOD AND MOUNTING CONFIGURATION

A DARALI® Cycloidal Reducer consists of three sub-assemblies: Input, Ring Gear, and Output. Illustration below depicts various input methods and mounting configurations

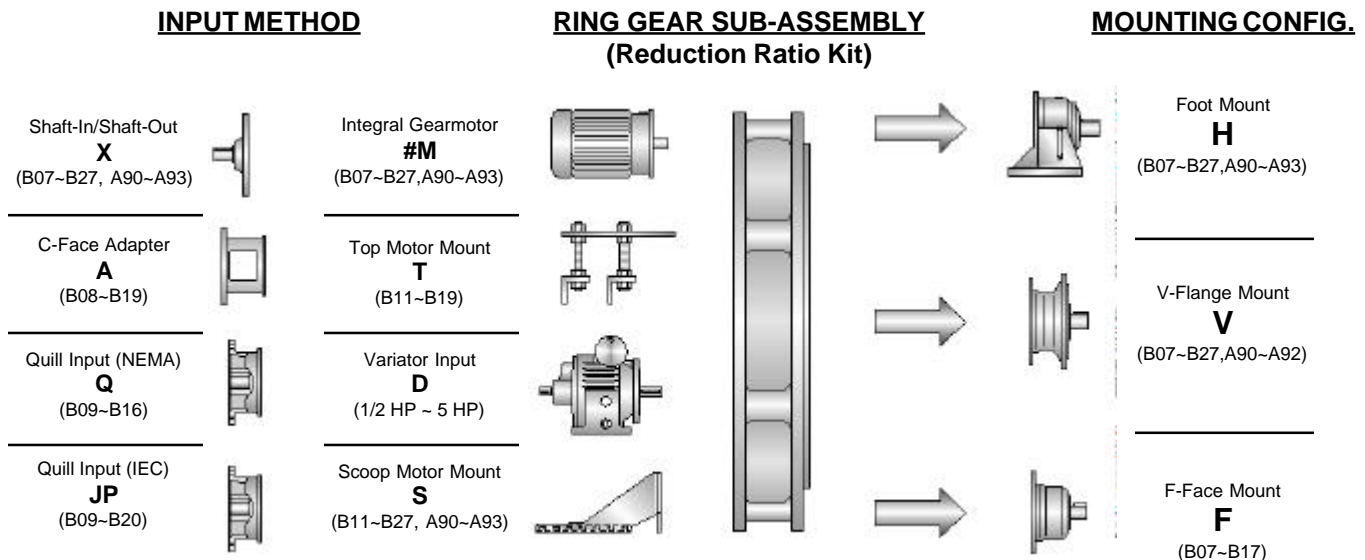

◆ DIRECTION OF OUTPUT SHAFT

Please make sure to install and operate this unit with output shaft pointing in the direction as specified by the part number.

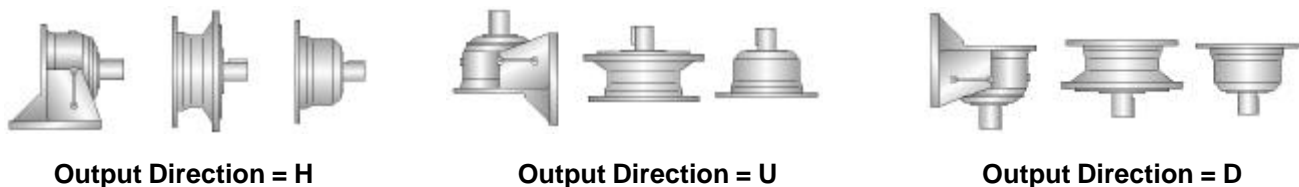

◆ SPECIAL FEATURES

Contact your Purchasing or Engineering Department to find out what S stands for. Factory can also provide you the information with the complete serial number.

WARNING

Protection guards for rotating shafts must be installed prior to use and thereafter must be used at all time. Install and operate DARALI® DRIVE in compliance with applicable local and national safety codes.

SAFE !

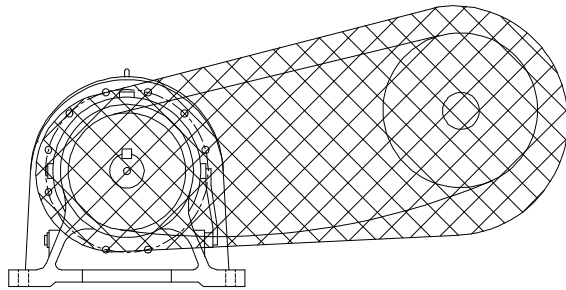

UNSAFE !

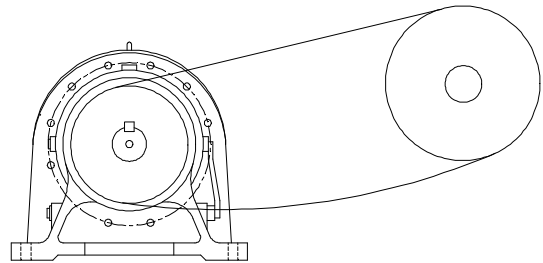

DETERMINE THE LUBRICATION METHOD OF THIS UNIT

◆ GREASE LUBRICATING UNITS

All grease lubricating units are identified with the tag shown on the right. These units are typically of frame sizes B07~B12 as well as all the vertical application units and the V-Flange mounting units. Double reduction units may be grease or oil lubricated depending on size, ratio, and/or application. Please refer to page 6 for further information on grease lubrication

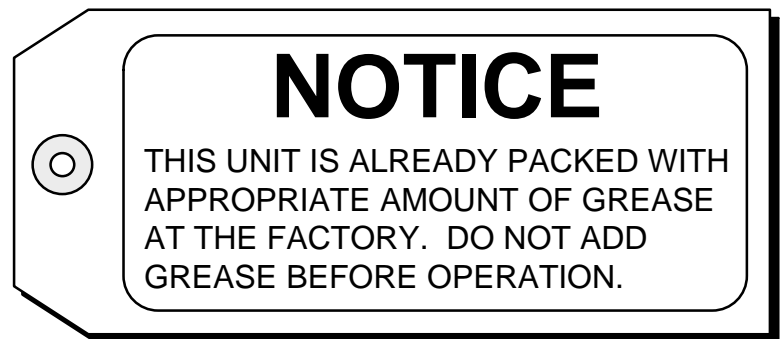

◆ OIL LUBRICATING UNITS

All oil lubricated units are identified with the tag shown on the right. These units are typically of frame sizes B13~B27 with foot mount for horizontal applications. Double reduction units may be grease or oil lubricated depending on size, ratio, and/or application. Please refer to page 5 for further information on oil lubrication

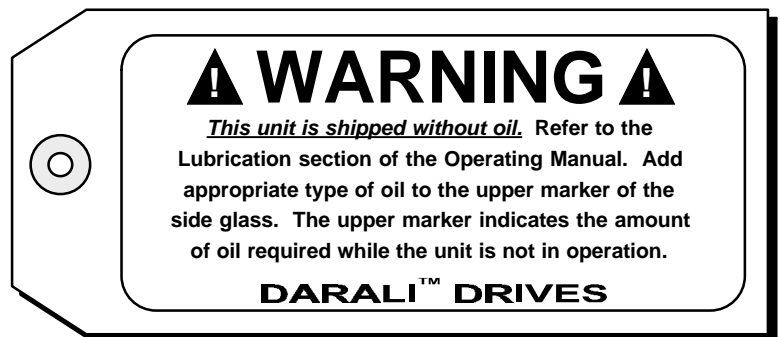

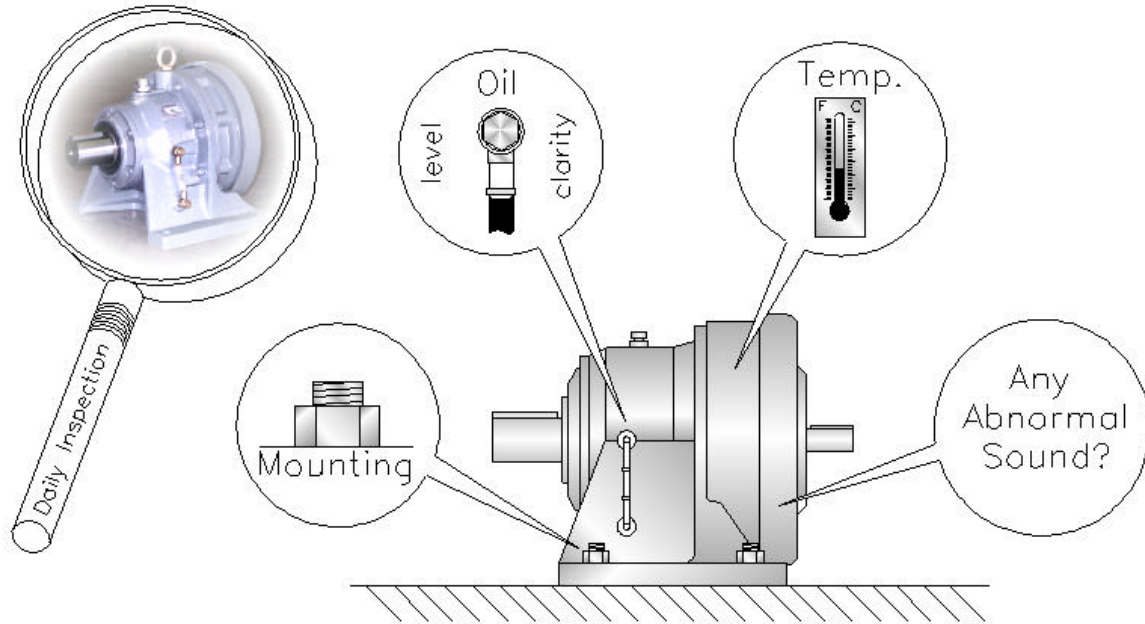

❑ MOUNTING FASTENERS

Inspect mounting bolts of the DARALI® Cycloidal Reducer to your equipment. Please make sure the foot or flange of speed reducer is tightened down rigidly to the mounting base. Tighten loose bolts as necessary. If bolts are loose frequently, reinforce the mounting structure and consider using double nuts on each bolt. Use bolts of ISO grade 8.8 minimum when mounting the flange or feet of the DARALI® Cycloidal Reducer to your equipment.

❑ LUBRICATING OIL

Check lubricating oil level. The oil level must be filled to the upper marker of side glass when the unit is not in operation. The oil level must be at least above the lower mark when the unit is in operation. Please be aware that the oil-lubricated double reduction models require extra oil to ensure the first reduction stage receives sufficient lubrication. Please refer to the lubrication section of this catalog or installation manual. Changing the lubricating oil frequently will further enhance the service life of DARALI® Cycloidal Reducers. Refer to the lubrication section of this catalog for further information.

❑ TEMPERATURE RISE

Any temperature rise up to 105 °F (58 °C) above ambient temperature on the surface of the ring gear housing is considered normal. Check for any rapid temperature rise from a stable operating condition. If such a phenomenon occur, add the recommended oil or grease (refer to the lubrication section). If the rapid temperature rise still persists, stop operation and contact factory.

❑ ABNORMAL SOUND

If you start hearing sudden abnormal sound generated from inside the unit, stop operation and inspect the unit. Check mounting bolts and the installation of sheaves and sprockets. Also check the tightness of fan guard and fan installation. Make sure there are sufficient lubrication inside the reducer. Please observe, lower reduction ratios of cycloidal cycloidal reducers are subject to higher operating sound level due to higher internal speed. This phenomenon is considered normal.

❑ MOUNTING PRECAUTION FOR THE F-TYPE UNITS

Unlike the H and V type units that have one set of fasteners to hold speed reducer together, and another set of fasteners to install the speed reducer onto the mounting surface, the F type units have only one set of fasteners that performs both functions. In this situation, loose bolts could result not only in insecure installation, but also the possible separation of speed reducer. Check the tightness of fasteners daily. This precautionary measure is especially important for applications involving frequent start/stop and reversing as well as application using brakes or clutches with the F-type mounting. We can provide you an extra set of nuts and washers so the original set can be used to hold speed reducer together, and the extra set can be used to mount the unit.

Make sure bolts are tight !!

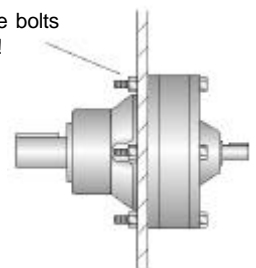

OIL LUBRICATION

- ◆ Lubrication oils on some models are drained before shipment. **Please check to make sure of appropriate oil supply before attempting operation.**
- ◆ Use low viscosity oil during winter or in low ambient temperature. Use high viscosity oil during summer or in high ambient temperature. Use **Mild EP Oil.**
- ◆ Please use lubrication oils recommended below. Do not mix different brands of oils.

AMBIENT TEMPERATURE	ISO VISCOSITY GRADE	AGMA VISCOSITY GRADE	SAE GRADE GEAR OIL
5°F ~ 32°F (-15°C ~ 0°C)	68	2EP	80W
32°F ~ 95°F (0°C ~ 35°C)	100 ~ 150	3EP 4EP	85W 90
95°F ~ 122°F (35°C ~ 50°C)	220 ~ 460	5EP 7EP	90 140

Approximate Volume of Oil Filling - Horizontal Configuration

Frame Size	B13	B14	B15	B16	B17	B18	B19	B20	B21	B22	B23	B24	B25	B26	B27
Volume in Gallon	0.2	0.2	0.2	0.4	0.5	0.6	1.1	1.5	2.3	2.6	4.0	4.2	5.6	7.7	14.8
Volume in Liter	0.7	0.7	0.7	1.4	1.9	2.5	4.0	5.5	8.5	9.8	15	16	21	28	56

Frame Size	B1611	B1711	B1813	B1911	B1913	B2011	B2013	B2113	B2116	B2213	B2217	B2316	B2318	B2416	B2418	B2517	B2519	B2619	B2719
Volume in Gallon	0.4	0.6	0.9	1.6	1.6	1.6	1.6	2.7	2.7	2.9	2.9	4.5	4.5	4.8	4.8	6.1	6.1	8.5	18.5
Volume in Liter	1.5	2.4	3.5	5.8	6.0	6.0	6.0	10	10	11	11	17	17	18	18	23	23	32	70

LUBRICATION FOR DOUBLE REDUCTION UNITS

- ◆ The following double reduction frame sizes are **grease lubricated on the first reduction stage, and oil lubricated on the second reduction stage:** *B1310, B1409, B1611, B1711, B1911, B2011.*

The first stage of above frame sizes are always packed with grease from the factory. Unless otherwise specified, the second stage of above frame sizes are empty without oil. You must add appropriate type and amount of oil before attempting operation.

- ◆ The following double reduction frame sizes are **oil lubricated on both first and second reduction stage:** *B1813, B1913, B2013, B2113, B2116, B2213, B2217, B2316, B2318, B2416, B2418, B2517, B2519, B2619, B2719.*

Unless otherwise specified, both reduction stages of above frame sizes are shipped empty without oil. You must add appropriate type and amount of oil before attempting operation. In order for the unit to run properly, you must have sufficient lubrication in both stages. See below for the oil filling recommendation. Insufficient oil amount will cause premature failure.

NOTE !

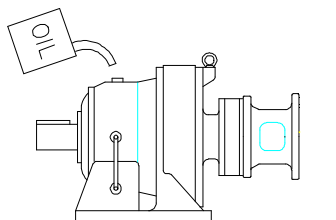

Oil flows slower toward the first reduction stage

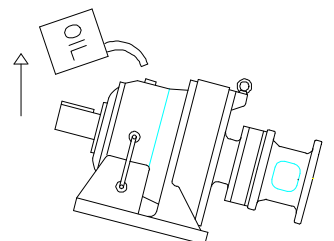

Raise the output shaft up helps oil reaching the first reduction stage easier and quicker.

OIL LUBRICATION REPLENISHMENT

- ◆ Under all operating conditions, DARALI® Cycloidal Reducer needs the initial oil change after 2 months of service.
- ◆ Based on an 8 hours per day application, subsequent oil change shall be performed every 6 months. For an 8 ~ 24 hours per day application, perform subsequent oil change every 2500 hours. A more frequent oil change will help achieving much longer service life.
- ◆ If this unit is running under heavy operating condition or in a high temperature, high humidity, or corrosive environment, the lubricants have to be changed more frequently. (i.e. every 1 ~ 3 months)

Oil Change Interval

OPERATING CONDITION	RECOMMENDED OIL CHANGE INTERVAL
Initial Oil Change	Two Months
Up to 8 Hours / Day	Every 6 Months
8 ~ 24 Hours / Day	Every 2500 Hours
High Temperature High Humidity	Every 1 ~ 3 Months

GREASE LUBRICATION

- ◆ Frame sizes B07~B12 are filled with appropriate amount of grease before leaving factory. Please do not refill upon receiving of DARALI® Cycloidal Reducers.
- ◆ Frame sizes B07~B12, filled with long duration grease as mentioned above, require no lubrication replenishment for 20,000 hours or 4~5 years of service.
- ◆ Depending on operating conditions, users may re-lubricate grease packed units as needed.
- ◆ If the unit experiences a sudden temperature rise, supply grease immediately.

Recommended Grease

AMBIENT TEMPERATURE	Single Reduction (6:1 ~ 87:1)		Double Reduction (121:1 ~ 7569:1)	
	Shell Oil	Mobile Oil	Shell Oil	Mobile Oil
5 °F (-15° C) to 122 °F (50° C)	Darina EP Grease No. 2	Mobilux EP2	Darina EP Grease No. 2	Mobilux EP2

NOTE !

Single Reduction, 6:1 ~ 87:1

Output Direction = Opposite of Input Direction

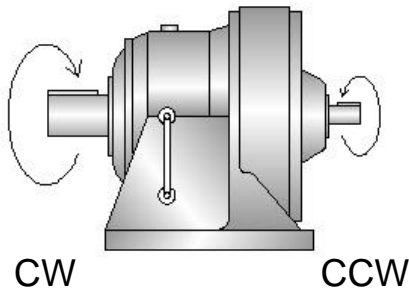

Double Reduction, 102:1 ~ 7569:1

Output Direction = Input Direction

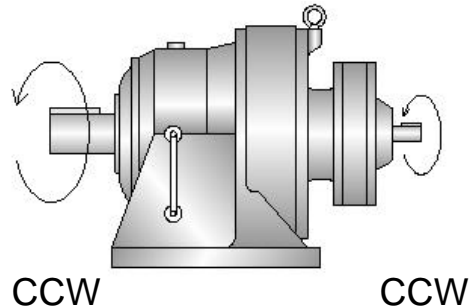

◆ PROPER LUBRICATION

Treat this DARALI® Cycloidal Reducer as your most precious automobile! The quality of lubricating oil has a direct influence on the service life of this unit. Use appropriate type and amount of lubrication. Depending on ambient temperature, use high viscosity oil for high ambient temperature environment (i.e. summer), and use low viscosity oil for low ambient temperature environment (i.e. winter).

◆ RIGID INSTALLATION

Use bolts of ISO grade 8.8 minimum when mounting the flange or feet of this DARALI® Cycloidal Reducer to your equipment. Please make sure the foot or flange of speed reducer is tightened down rigidly to the mounting base. Loosened mounting bolts may cause the vibration of speed reducer which could eventually contribute to foot breakage. **Observe the mounting condition frequently.** If necessary, use higher grade fasteners and double nuts on each bolt.

◆ CORRECT INSTALLATION OF SPROCKET, CHAIN, SHEAVE, AND BELT

Proper installation of sprocket and chain can minimize overhung load on input and output shafts. **Apply anti-seize compound on the shaft before installing sheave or sprocket.** Sprockets and sheaves should be installed as close to the collar surface as possible. Chains should be slack on the non-pulling side. In addition, align sheaves and pulleys correctly. Practicing the above installation instructions can help decreasing the stress on shaft bearings. **Overtightening of chain or belt increases the overhung load on the speed reducer shaft dramatically.**

◆ ACCURATE ALIGNMENT OF COUPLING

Make sure to align the shaft accurately when connecting this speed reducer to motor and/or driven machine. **Apply anti-seize compound on the shaft before installing coupling.**

◆ ALWAYS USE PROTECTION GUARDS FOR ROTATING SHAFTS

SAFE !

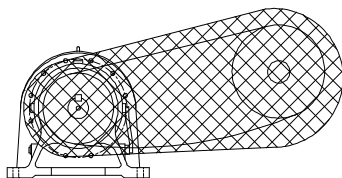

UNSAFE !

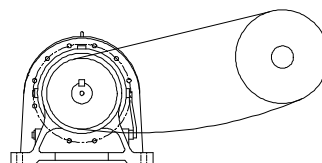

✓ GOOD !

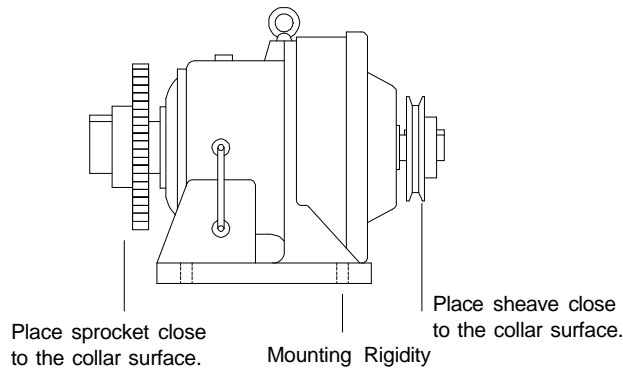

X BAD !

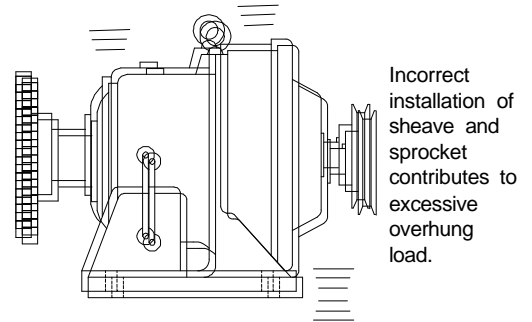

✓ GOOD !

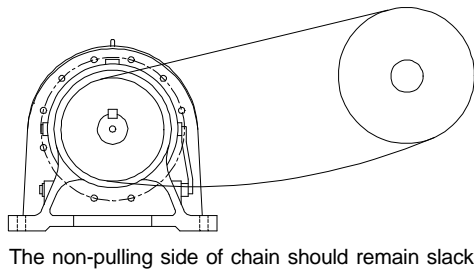

X BAD !

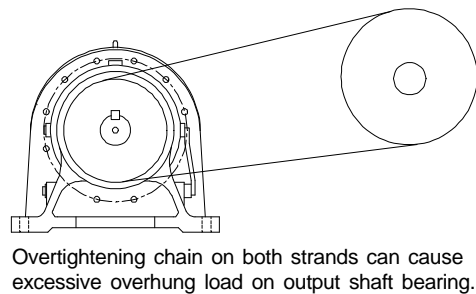

✓ GOOD !

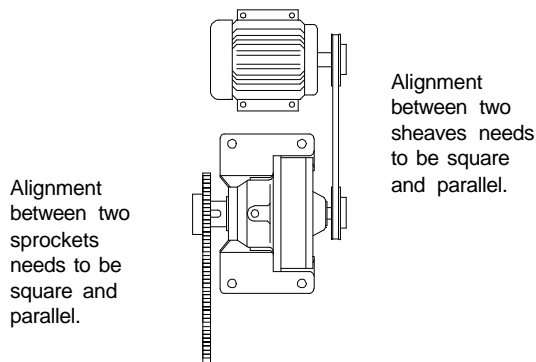

X BAD !

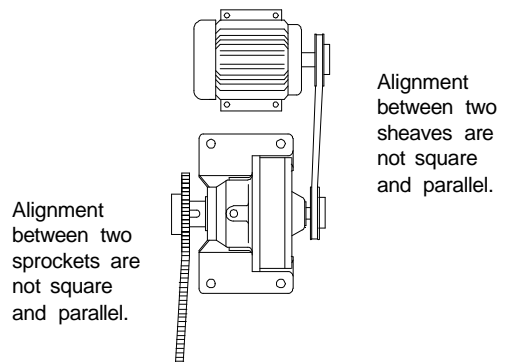

✓GOOD !

X BAD !

X BAD !

✓GOOD !

X BAD !

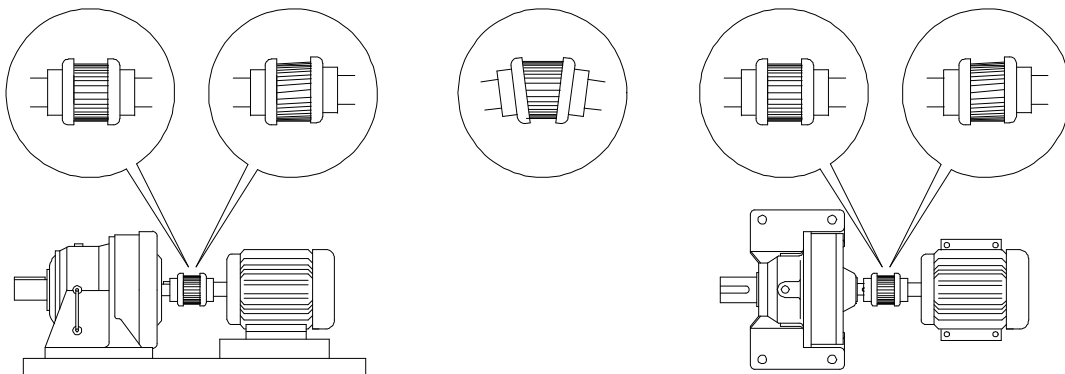

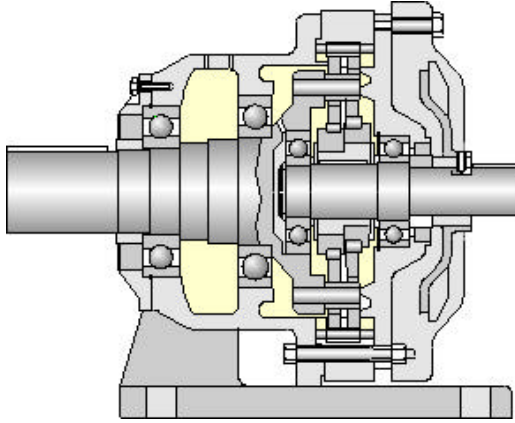

Each DARALI® Cycloidal Speed Reducer is constructed with three major sub-assemblies: output sub-assembly, ring gear sub-assembly, and input sub-assembly.

The input and output sub-assemblies are generic within each frame size. That is, disregard what the reduction ratio is (between 6:1 and 87:1), the same input and output assemblies are used to assemble speed reducers in the same frame size. The ring gear sub-assembly determines the reduction ratio of a DARALI® Cycloidal Reducer.

Listed below are the code names for each component inside the cycloidal speed reducer. This Parts List includes only components that may require repair or replacement during the rebuild. Components that are very unlikely to subject to replacement are not listed here.

<p>OUTPUT SUB-ASSEMBLY <i>*Generic within each frame</i></p> <p>Major Components: L1 - Output Casting L2 - Oil Seal L3 - Slow Speed Shaft with Pins L4A - Slow Speed Shaft Bearing L4B - Slow Speed Shaft Bearing L5 - Oil Filler Cap (B13 and above) L6 - Oil Seal Housing (B13 and above) L7 - High Speed Shaft End Bearing</p>	<p>RING GEAR SUB-ASSEMBLY <i>*The Reduction Ratio Kit</i></p> <p>Major Components: R1 - Ring Gear Casting R2 - Ring Gear Pins/Rollers R3 - Cycloidal Disc(s) (B07~B09: 1 Disc w/ Counter Weight. B10 and above: 2 discs) R4 - Cycloidal Disc Spacer (B10 and above) R5 - Eccentric Bearing R6 - Slow Speed Shaft Rollers R7 - Bearing Spacers R8 - Snap Ring R9 - Gasket Set</p>	<p>INPUT SUB-ASSEMBLY <i>*Generic within each frame</i></p> <p>Major components: H1 - Input Cap H2 - Oil Seal H3 - Cooling Fan (B16 and above) H3A - Fan Cover (B16 and above) H4 - High Speed Shaft H5 - High Speed Shaft Bearing</p>

Frame Parts	B07	B08	B09	B10	B11	B12	B13	B14	B15	B16	B17	B18	B19
L1	B07H-L1	B08H-L1	B09H-L1	B10H-L1	B11H-L1	B12H-L1	B13H-L1	B14H-L1	B15H-L1	B16H-L1	B17H-L1	B18H-L1	B19H-L1
L2	35x47x8	35x47x8	40x72x10	40x72x10	65x90x12	65x90x12	65x90x12	65x90x12	65x90x12	85x110x13	95x130x14	110x145x14	120x155x15
L3	B07-L3	B08-L3	B09-L3	B10-L3	B11-L3	B12-L3	B13-L3	B14-L3	B15-L3	B16-L3	B17-L3	B18-L3	B19-L3
L4A	6005	6005	6306	6306	6308	6308	6211NR	22211NR	22211NR	6213NR	6216NR	6218NR	6221NR
L4B	6008	6008	6011	6011	6013	6013	6213	6213	6213	6215	6218	6220	6026
L5	--	--	--	--	--	--	L5	L5	L5	L5	L5	L5	L5
L6	--	--	--	--	--	--	B13-L6	B14-L6	B15-L6	B16-L6	B17-L6	B18-L6	B19-L6
L7	6200	6200	6302	6302	6304	6304	6305	6305	6305	6307	6406	6407	6408
R1	See Note	See Note	See Note	See Note	See Note	See Note	See Note	See Note	See Note	See Note	See Note	See Note	See Note
R2	See Note	See Note	See Note	See Note	See Note	See Note	See Note	See Note	See Note	See Note	See Note	See Note	See Note
R3	See Note	See Note	See Note	See Note	See Note	See Note	See Note	See Note	See Note	See Note	See Note	See Note	See Note
R4	--	--	--	B10-R4	B11-R4	B12-R4	B13-R4	B14-R4	B15-R4	B16-R4	B17-R4	B18-R4	B19-R4
R5	B07-EB-?	B08-EB-?	B09-EB-?	B10-EB-?	B11-EB-?	B12-EB-?	B13-EB-?	B14-EB-?	B15-EB-?	B16-EB-?	B17-EB-?	B18-EB-?	B19-EB-?
R6	B07-R6	B08-R6	B09-R6	B10-R6	B11-R6	B12-R6	B13-R6	B14-R6	B15-R6	B16-R6	B17-R6	B18-R6	B19-R6
R7	B07-R7	B08-R7	B09-R7	B10-R7	B11-R7	B12-R7	B13-R7	B14-R7	B15-R7	B16-R7	B17-R7	B18-R7	B19-R7
R8	--	--	--	--	S-20	S-20	S-25	S-25	S-25	S-35	S-30	S-35	S-40
R9	B07-R9	B08-R9	B09-R9	B10-R9	B11-R9	B12-R9	B13-R9	B14-R9	B15-R9	B16-R9	B17-R9	B18-R9	B19-R9
H1	B07-H1	B08-H1	B09-H1	B10-H1	B11-H1	B12-H1	B13-H1	B14-H1	B15-H1	B16-H1	B17-H1	B18-H1	B19-H1
H2	17x30x8	17x30x8	20x35x8	20x35x8	32x52x10	32x52x10	38x58x9	38x58x9	38x58x9	55x78x12	60x82x12	65x88x12	85x110x12
H3	--	--	--	--	--	--	--	--	--	B16-H3	B17-H3	B18-H3	B19-H3
H3A	--	--	--	--	--	--	--	--	--	B16-H3A	B17-H3A	B18-H3A	B19-H3A
H4	B07-H4	B08-H4	B09-H4	B10-H4	B11-H4	B12-H4	B13-H4	B14-H4	B15-H4	B16-H4	B17-H4	B18-H4	B19-H4
H5	6301	6301	6302	6302	6305	6305	6306	6306	6306	6308	6407	6409	6411

Note:

- Ring Gear Sub-Assembly is typically sold as one set instead of individual components.
- When purchasing Eccentric Bearing (R5), please specify eccentricity. Eccentricity can be measured using the following method.

$$\text{Eccentricity} = (A-B) / 2$$

Where,

A = Diameter of Planetary Bore

B = Outside Diameter of Output Shaft Roller

* Both A & B have to be measured in mm. We recommend not to measure A & B in inches and then convert. Error may occur when converting from inch to mm.

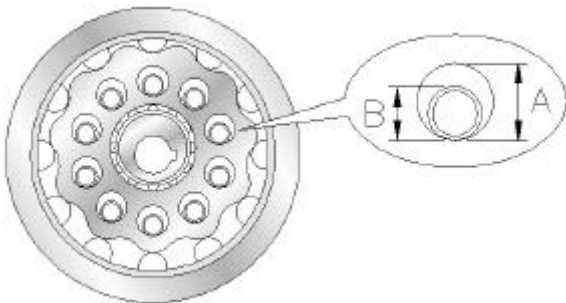

- Therefore, when ordering Eccentric Bearing (R5), the "?" in the part number denotes eccentricity, and eccentricity can be determined using the above measurement.

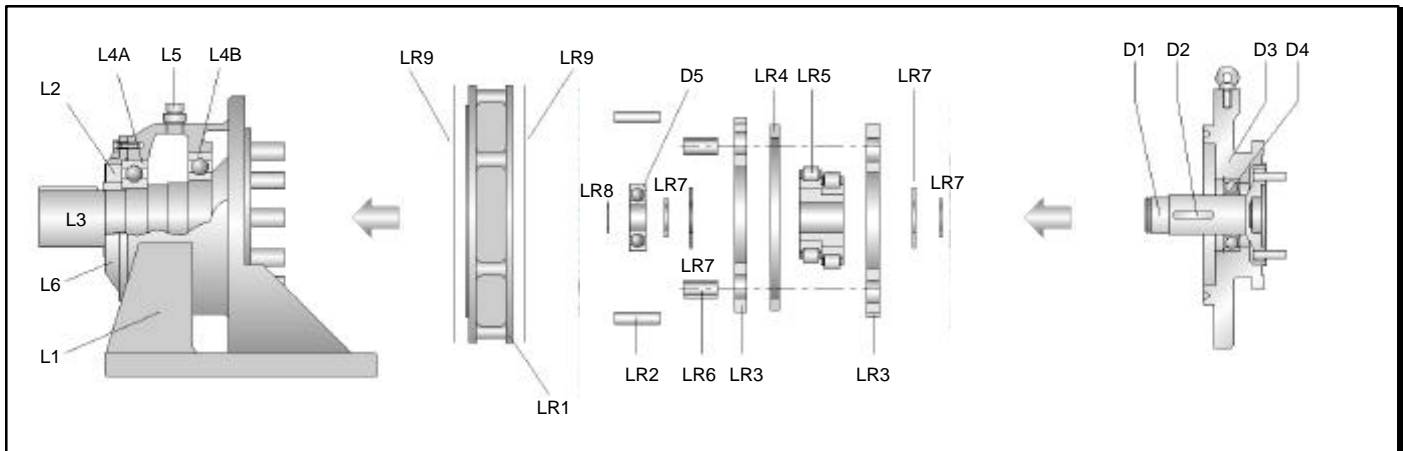

OUTPUT SUB-ASSEMBLY

Major Components:

- L1** - Output Casting
- L2** - Oil Seal
- L3** - Slow Speed Shaft with Pins
- L4A** - Slow Speed Shaft Bearing
- L4B** - Slow Speed Shaft Bearing
- L5** - Oil Filler Cap (B13 and above)
- L6** - Oil Seal Housing (B13 and above)
- D5** - Double Stage Shaft End Bearing

RING GEAR SUB-ASSEMBLY

(Second Stage Ring Gear)

Major Components:

- LR1** - Ring Gear Casting
- LR2** - Ring Gear Pins/Rollers
- LR3** - Cycloidal Disc(s)
(B07~B09: 1 Disc w/ Counter Weight. B10 and above: 2 discs)
- LR4** - Cycloidal Disc Spacer
(B10 and above)
- LR5** - Eccentric Bearing
- LR6** - Slow Speed Shaft Rollers
- LR7** - Bearing Spacers
- LR8** - Snap Ring
- LR9** - Gasket Set

DOUBLE STAGE KIT

(Connects First Stage and Second Stage Ring Gears)

Major components:

- D1** - Double Stage Intermediate Shaft
- D2** - Eccentric Bearing Key
- D3** - Double Stage Casting
- D4** - Double Stage Shaft Bearing
- H6** - High Speed Shaft End Bearing
(please refer to the diagram below)

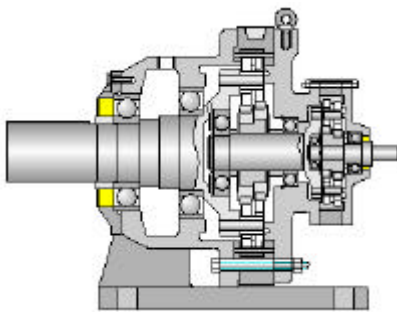

EXAMPLE:

B1711-1849:1-XHH

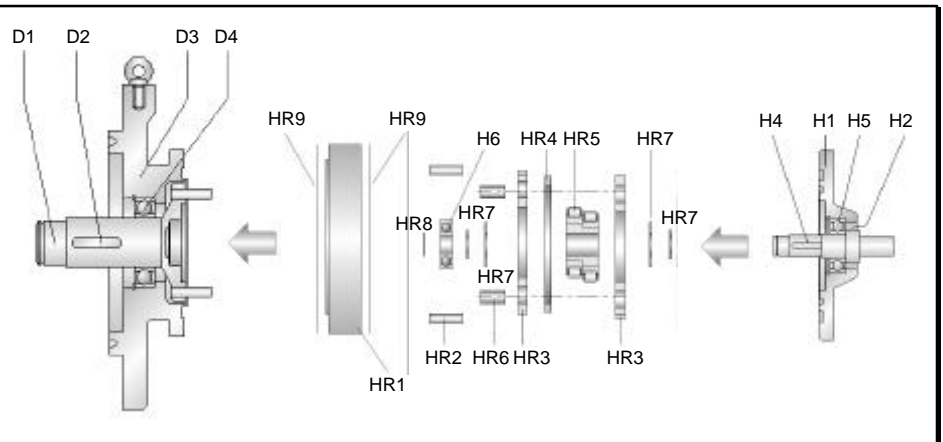
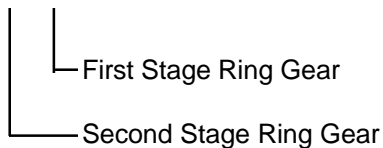

RING GEAR SUB-ASSEMBLY

(First Stage Ring Gear)

Major Components:

- HR1** - Ring Gear Casting
- HR2** - Ring Gear Pins/Rollers
- HR3** - Cycloidal Disc(s)
(B07~B09: 1 Disc w/ Counter Weight. B10 and above: 2 discs)
- HR4** - Cycloidal Disc Spacer
(B10 and above)
- HR5** - Eccentric Bearing
- HR6** - Slow Speed Shaft Rollers
- HR7** - Bearing Spacers
- HR8** - Snap Ring
- HR9** - Gasket Set

INPUT SUB-ASSEMBLY

Major components:

- H1** - Input Cap
- H2** - Oil Seal
- H4** - High Speed Shaft
- H5** - High Speed Shaft Bearing
- H6** - High Speed Shaft End Bearing

Frame Parts	B0908	B1008	B1109	B1310	B1409	B1611	B1711	B1813	B1911	B1913
L1	B09H-L1	B10H-L1	B11H-L1	B13H-L1	B14H-L1	B16H-L1	B17H-L1	B18H-L1	B19H-L1	B19H-L1
L2	40x72x10	40x72x10	65x90x12	65x90x12	65x90x12	85x110x13	95x130x14	110x145x14	120x155x15	120x155x15
L3	B09-L3	B10-L3	B11-L3	B13-L3	B14-L3	B16-L3	B17-L3	B18-L3	B19-L3	B19-L3
L4A	6306	6306	6308	6211NR	22211NR	6213NR	6216NR	6218NR	6221NR	6221NR
L4B	6011	6011	6013	6213	6213	6215	6218	6220	6026	6026
L5	--	--	--	L5	L5	L5	L5	L5	L5	L5
L6	--	--	--	B13-L6	B14-L6	B16-L6	B17-L6	B18-L6	B19-L6	B19-L6
L7	6302	6302	6304	6305	6305	6307	6406	6407	6408	6408
LR1	See Note	See Note	See Note	See Note	See Note	See Note	See Note	See Note	See Note	See Note
LR2	See Note	See Note	See Note	See Note	See Note	See Note	See Note	See Note	See Note	See Note
LR3	See Note	See Note	See Note	See Note	See Note	See Note	See Note	See Note	See Note	See Note
LR4	--	B10-R4	B11-R4	B13-R4	B14-R4	B16-R4	B17-R4	B18-R4	B19-R4	B19-R4
LR5	B09-EB-?	B10-EB-?	B11-EB-?	B13-EB-?	B14-EB-?	B16-EB-?	B17-EB-?	B18-EB-?	B19-EB-?	B19-EB-?
LR6	B09-R6	B10-R6	B11-R6	B13-R6	B14-R6	B16-R6	B17-R6	B18-R6	B19-R6	B19-R6
LR7	B09-R7	B10-R7	B11-R7	B13-R7	B14-R7	B16-R7	B17-R7	B18-R7	B19-R7	B19-R7
LR8	--	--	S-20	S-25	S-25	S-35	S-30	S-35	S-40	S-40
LR9	B09-R9	B10-R9	B11-R9	B13-R9	B14-R9	B16-R9	B17-R9	B18-R9	B19-R9	B19-R9
D1	B0908-D1	B1008-D1	B1109-D1	B1310-D1	B1409-D1	B1611-D1	B1711-D1	B1813-D1	B1911-D1	B1913-D1
D2	B0908-D2	B1008-D2	B1109-D2	B1310-D2	B1409-D2	B1611-D2	B1711-D2	B1813-D2	B1911-D2	B1913-D2
D3	B0908-D3	B1008-D3	B1109-D3	B1310-D3	B1409-D3	B1611-D3	B1711-D3	B1813-D3	B1911-D3	B1913-D3
D4	6302	6302	6205	6206	6206	6208	6208	6213	6210	6213
HR1	See Note	See Note	See Note	See Note	See Note	See Note	See Note	See Note	See Note	See Note
HR2	See Note	See Note	See Note	See Note	See Note	See Note	See Note	See Note	See Note	See Note
HR3	See Note	See Note	See Note	See Note	See Note	See Note	See Note	See Note	See Note	See Note
HR4	--	--	--	B10-R4	--	B11-R4	B11-R4	B13-R4	B11-R4	B13-R4
HR5	B08-EB-?	B08-EB-?	B09-EB-?	B10-EB-?	B09-EB-?	B11-EB-?	B11-EB-?	B13-EB-?	B11-EB-?	B13-EB-?
HR6	B08-R6	B08-R6	B09-R6	B10-R6	B09-R6	B11-R6	B11-R6	B13-R6	B11-R6	B13-R6
HR7	B08-R7	B08-R7	B09-R7	B10-R7	B09-R7	B11-R7	B11-R7	B13-R7	B11-R7	B13-R7
HR8	--	--	--	--	--	S-20	S-20	S-25	S-20	S-25
HR9	B08-R9	B08-R9	B09-R9	B10-R9	B09-R9	B11-R9	B11-R9	B13-R9	B11-R9	B13-R9
H1	B08-H1	B08-H1	B09-H1	B10-H1	B09-H1	B11-H1	B11-H1	B13-H1	B11-H1	B13-H1
H2	17x30x8	17x30x8	20x35x8	20x35x8	20x35x8	32x52x10	32x52x10	38x58x9	32x52x10	38x58x9
H4	B08-H4	B08-H4	B09-H4	B10-H4	B09-H4	B11-H4	B11-H4	B13-H4	B11-H4	B13-H4
H5	6301	6301	6302	6302	6302	6305	6305	6306	6305	6306
H6	6200	6200	6302	6302	6302	6204	6204	6305	6304	6305

Note:

- Ring Gear Sub-Assembly is typically sold as one set instead of individual components.
- When purchasing Eccentric Bearing (LR5 or HR5), please specify eccentricity. Eccentricity can be measured using the following method.

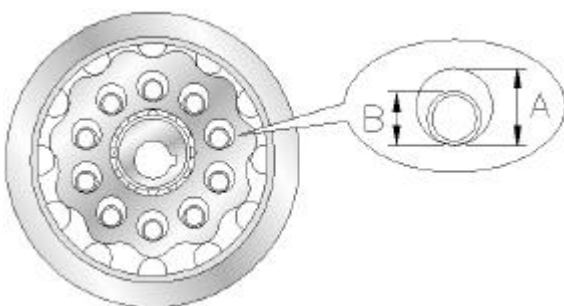

$$\text{Eccentricity} = (A-B) / 2$$

Where,

A = Diameter of Planetary Bore

B = Outside Diameter of Output Shaft Roller

* Both A & B have to be measured in mm. We recommend not to measure A & B in inches and then convert. Error may occur when converting from inch to mm.

- Therefore, when ordering Eccentric Bearing (LR5 or HR5), the “?” in the part number denotes eccentricity, and eccentricity can be determined using the above measurement.

☐ TEFC AC Induction Motors

☐ 3-Phase 60 Hz or 50 Hz, 230/460V, 220/380V, 208/415V, 220/440V, 575V

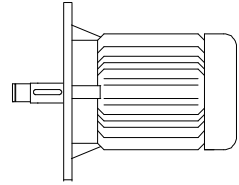

230/460 VAC, 60 Hz, Continuous Duty, TEFC

Output		Full Load rpm	Motor Frame	Full Load Characteristic					Starting Torque		Max. Torque %	Inertia	
hp	kW			Torque		Effic. %	Power Factor	Amp	% of F.L.	Amp		kg-m ²	lb-in ²
1/4	0.185	1650	63	0.110	9.5	66.0	70.0	1.0	280	6	250	0.003	10.3
		1120	71	0.162	14.1	64.0	60.0	1.3	200	6	250	0.006	20.5
1/2	0.37	1680	71	0.216	18.7	70.0	75.0	1.9	200	12	250	0.005	17.1
		1130	80	0.321	27.9	68.0	67.0	2.2	200	12	230	0.009	30.8
1	0.75	1700	80	0.427	37.1	76.0	76.5	3.4	230	19	280	0.009	30.8
		1140	90 L	0.637	55.3	76.0	71.0	3.6	200	19	230	0.018	61.5
2	1.5	1710	90 L	0.849	73.7	79.0	81.0	6.1	220	40	280	0.018	61.5
		1140	100 L	1.273	110	78.0	74.0	6.8	180	40	220	0.033	113
3	2.2	1725	100 L	1.262	110	82.0	82.5	8.7	210	68	260	0.033	113
		1150	112 M	1.894	164	82.0	77.0	9.3	180	68	230	0.060	205
5	3.7	1745	112 M	2.080	181	85.0	85.0	13.5	220	110	260	0.060	205
		1160	132 S	3.129	272	84.0	77.0	15.1	180	110	230	0.154	526
7 1/2	5.5	1750	132 S	3.111	270	87.0	84.0	20.1	220	160	250	0.106	362
		1160	132 M	4.693	407	85.0	77.5	22.3	200	160	230	0.222	759
10	7.5	1750	132 M	4.148	360	88.5	88.0	25.1	220	200	250	0.146	499
		1170	160 M	6.204	538	87.0	80.0	28.1	210	200	230	0.408	1394
15	11	1760	160 M	6.186	537	90.0	89.0	36.7	220	290	250	0.322	1100
		1170	160 L	9.306	808	89.5	84.0	39.1	210	290	230	0.599	2047
20	15	1760	160 L	8.248	716	90.5	86.0	50.3	220	360	240	0.412	1408
		1170	180 MC	12.41	1077	90.0	85.0	51.2	200	360	210	1.007	3441
25	18.5	1765	180 MC	10.28	892	91.0	85.5	62.9	210	440	240	0.624	2132
		1170	180 LC	15.51	1346	90.0	84.5	64.4	200	440	210	1.170	3998
30	22	1765	180 MC	12.34	1071	91.5	88.0	72.9	210	550	240	0.671	2293
		1170	180 LC	18.61	1615	91.0	84.0	76.8	200	550	210	1.365	4664
40	30	1760	180 LC	16.50	1432	92.0	88.0	96.7	210	620	230	0.829	2833
		1170	180 LC	24.82	2154	92.0	85.0	100.1	190	620	200	1.952	6670
50	37	1760	200 LC	20.60	1788	92.0	86.0	124.0	200	800	210	1.293	4418
		1170	200 LC	31.02	2692	92.5	84.0	126.0	190	800	200	2.292	7832
60	45	1760	200 LC	24.75	2148	92.0	89.0	143.5	190	910	200	1.681	5744
		1170	225 SC	37.22	3231	92.5	86.0	147.7	170	910	200	3.201	10938
75	55	1765	225 SC	30.84	2677	92.5	86.5	183.5	180	1220	200	1.947	6653

☞ Standard Motor Wiring Diagram

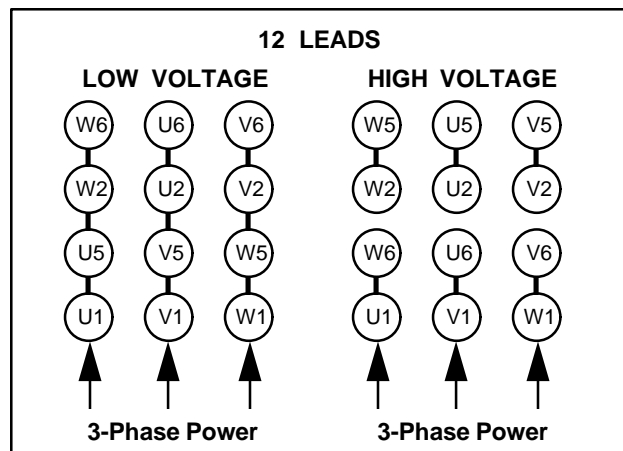
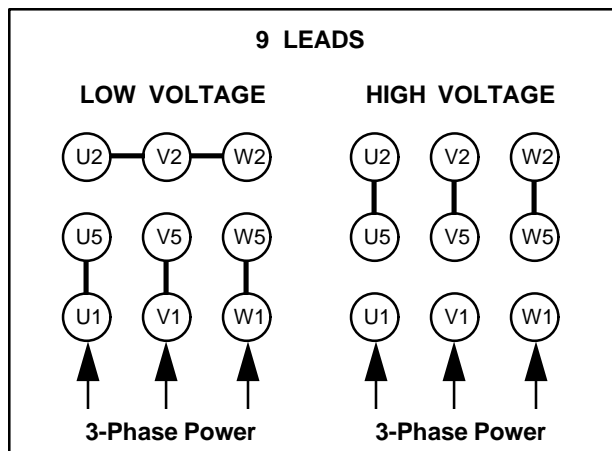

◆ DARALI®DRIVES Brakemotor comes with either a 9-lead or 12-lead junction box. Please refer to the diagram below for wiring connections of motor as well as power supply to the 90VDC rectifier. DARALI®DRIVES Brakemotors are pre-wired for 460 VAC at the factory. If your power supply is 460 VAC, no wiring changes are needed. Simply connect your power supply to the leads shown below. If your power supply is 230 VAC, first determine whether the motor is 9-lead or 12-lead, then connect the motor wiring and rectifier wiring according to the diagram.

